



Buzon®



www.buzon-world.com



**THE ESSENTIAL
IS INVISIBLE TO
THE EYE**

Saint-Exupery

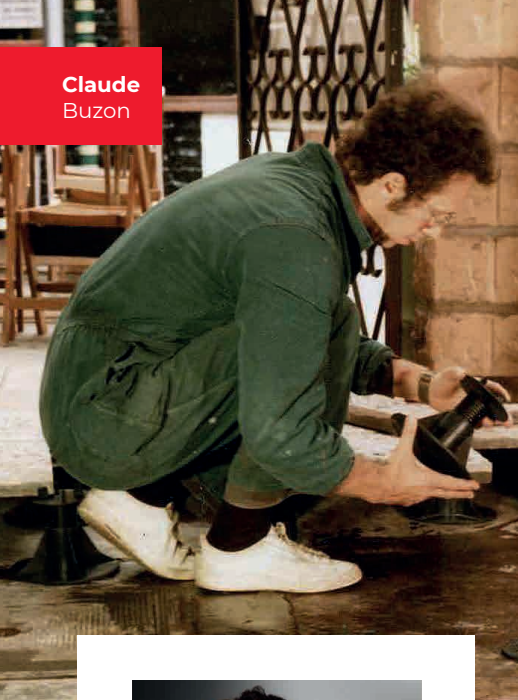

Three decades of innovations

Thirty years ago, Claude Buzon revolutionized the world of terrace support systems by founding Buzon Pedestal International. Since then the family has grown and thrived: surrounded by his children Laure and Laurent, no fewer than four generations of pedestals have subsequently seen the light of day. Our mission? To move heaven and earth to help our customers transform their outdoor spaces into the living spaces of their dreams.

We have achieved this success by building on solid foundations. Since its establishment in the Hauts Sarts enterprise park, our family company has never hesitated to reach out and now has 25 partners in more than 50 countries. Trust is one of our core values, and is reinforced during each mission: by taking time to listen to the client and rolling out each project with enthusiasm.

adapted and efficient products. In doing so, we place a special emphasis on the environment, in particular by using recycled raw materials and delivering 100% recyclable products. In addition to reducing our carbon footprint, we are also compensating for it by planting trees in Madagascar. Today, we are therefore proud to be able to post a CO₂ neutral balance sheet.

Although we offer stability solutions, we categorically reject the idea of standing still. Innovation is one of Buzon's drivers, which incites us to develop ever more



Laure Buzon



Laurent Buzon

25

PARTNERS



50

COUNTRIES

Our partners worldwide

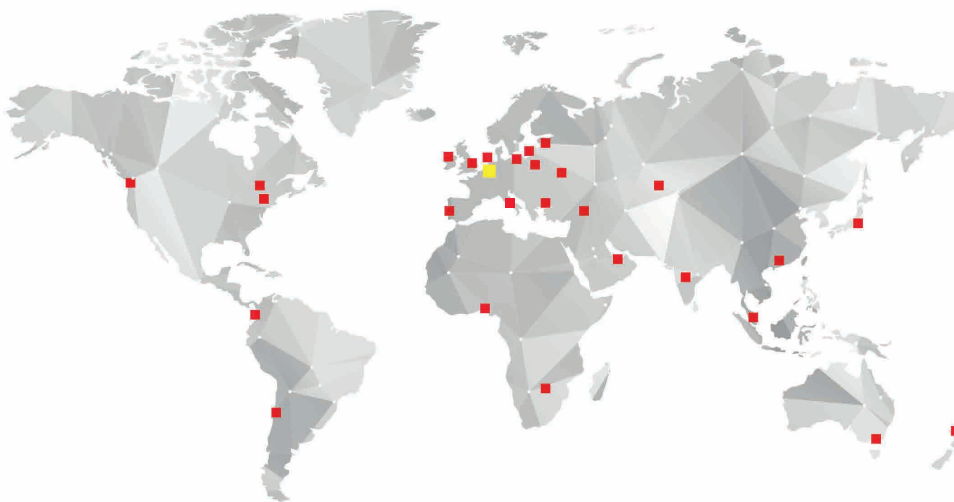

References

- Marina Bay Sands Hotel Singapore
- Seat of the EU Parliament, Brussels - Belgium
- Tokyo National Museum Japan
- University of Kansas USA
- University of Denver, Colorado
- Disneyland Paris, France
- ...





Who are we ?

Buzon is a dynamic team that attentively accompanies anyone wishing to benefit from a high-level technical expertise to create their outdoor living space.

What do we do ?

We develop innovative, ergonomic and sustainable products in the field of support systems.

We do so by surrounding ourselves with passionate, faithful and trustworthy partners and employees.



SHARING OUR CUSTOMERS' DREAMS

Claude
Buzon
5 JUNE 1983

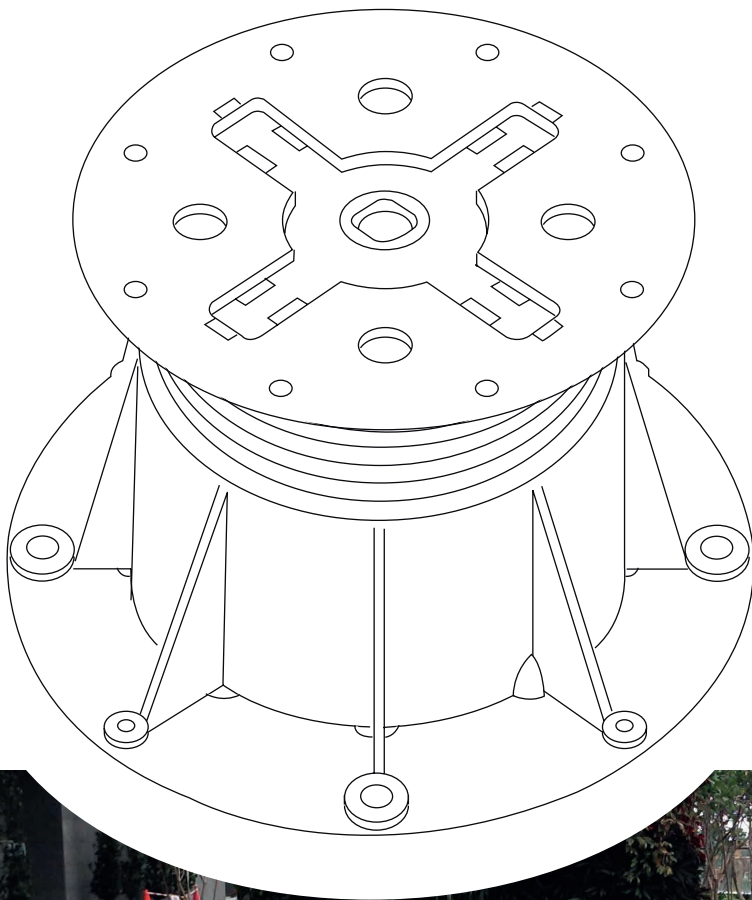

What drives us?

Our company values are:

Quality

We pay particular attention to the quality of our services, our products and to the relationship we nurture with each of our customers, but also with our suppliers.

Trust

The story of Buzon is based on the trust placed in our partners and our employees, through the autonomy we give them in each project.

Team spirit

Our family business promotes team spirit and solidarity. It is thanks to this collaboration and the constant support of each of our employees that we consistently make a success of every new challenge.

Ethics

Ethics is a high priority for Buzon. We make sure that everyone is respected and that their opinion is taken on board. We also take our corporate social responsibility very seriously. This is why we make sure that every project is done with respect for the environment.



Our support systems...

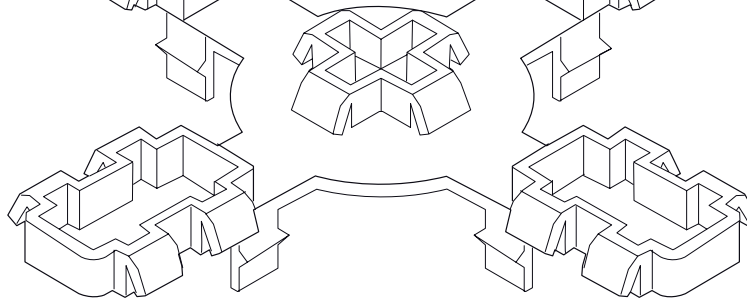

PB-SERIE

The second-to-last among the Buzon® pedestals, Buzon® PB-Series pedestals

and their many accessories are suitable whatever the ground covering you choose for your residential projects.



DPH-SERIE

The integrated slope corrector (0 - 5%) and the robustness make DPH-Series Buzon® pedestals

the ideal solution for all commercial, industrial and public projects.



BC-SERIE

The BC-Series gives terrace designers unparalleled freedom

thanks to the tabs that fit your polygonal tiles.

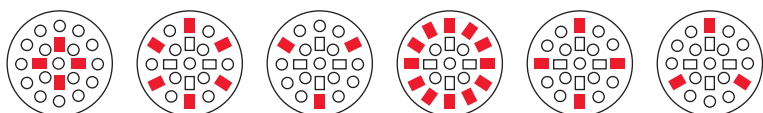

...for the creation of living spaces



Our pedestals offer a host of solutions for...

- Swimming pools
- Flat roofs
- Fountains
- Industrial flooring
- Illuminated flooring
- Gardens
- Balconies



Buzon Pedestal International S.A. • Registered Office

Prolongement de l'Abbaye, 134 - 4040 HERSTAL - BELGIUM
Tel: +32 (0)4 248 39 83 • Fax: +32 (0)4 264 82 38 • Email : sales@bpi.be